

FEPAT TEX

EYELETS

ACCESSORIES

TEXTILES

MACHINES

PROFITEX



FEPATEX
EYELETS | ACCESSORIES | TEXTILES | MACHINES

Get to know Fepatex

Fepatex is a leading producer and supplier of high-quality eyelets, accessories and smart solutions for the manufacturing industry. We support a wide range of sectors, including sign making, sailmaking, tents, sun protection, curtains, automotive, fashion and graphics.

What makes us different is that we offer complete solutions to help our customers work more efficiently, improve ergonomics and optimize their production.

We design and build smart eyelet machines, set up workstations with modular tables, provide user-friendly transport systems and effective winding and unwinding solutions. With our custom engineering, we make sure every production environment is precisely customized to the specific needs of our customers.

Our passion

At Fepatex, your needs come first in everything we do. We believe that real progress comes from innovation, quality and working closely with our customers. Our Profitex line is designed to help your company work smarter, faster, ergonomic and in a more sustainable way, so our customers can focus on what truly matters.

With Fepatex, you get more than premium products. You also get expert advice, practical support and a reliable partner.

Our customers appreciate our flexibility, clear communication and our commitment to help them succeed.

No matter where you're located, you can rely on Fepatex for smart solutions and hands-on support that keep your production running smoothly and efficiently.

Our mission

At Fepatex, our mission is to help the manufacturing industry become stronger, smarter and more sustainable. We do this by providing high-quality eyelets, accessories, textiles and custom Profitex solutions that make work easier, lower costs and support safe and responsible practices.

We create efficient and ergonomic workplaces, so our customers can stay competitive, keep up with changes to turn great ideas into quality products. Together, we're building a future where efficiency, quality and sustainability go hand in hand and where our customers continue to create beautiful things every day.

Your reliable partner for an innovative, sustainable and efficient manufacturing industry.

- ▶ Eyelets
- ▶ Accessories
- ▶ Textiles
- ▶ Machines
- ▶ Profitex

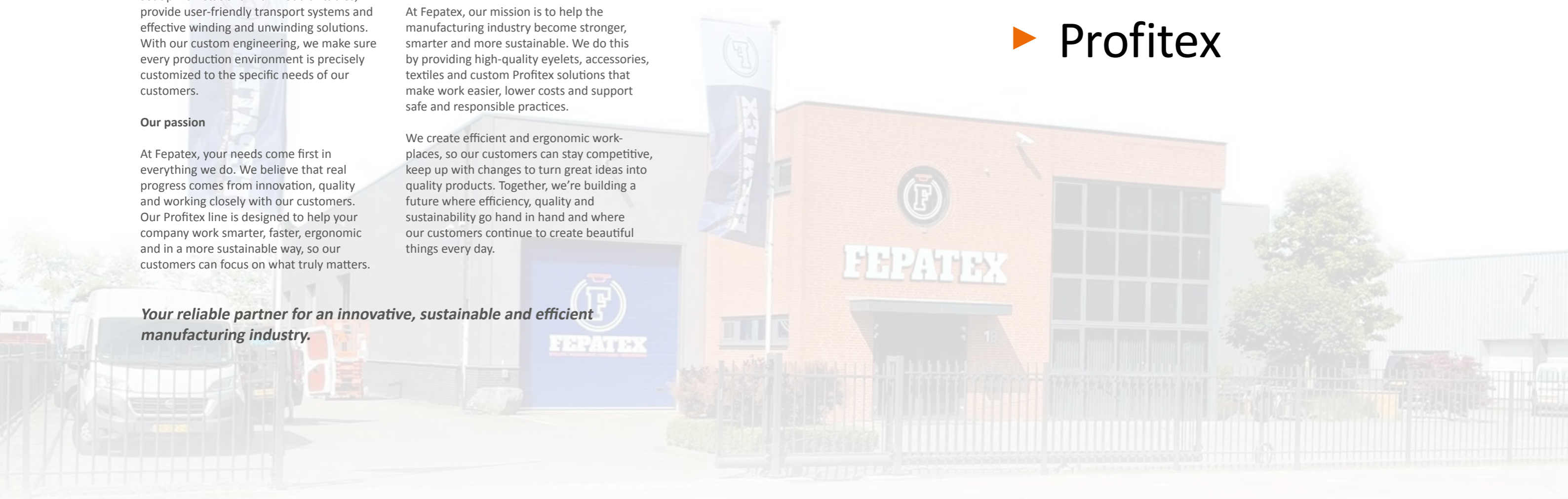



NICKEL

		A	B	C	MOQ
1184.1005.0002	Eyelets FP10-M	10	18	6,8	1.000
1184.1205.0002	Eyelets FP12-M	12	22	8,1	1.000
1184.1405.0002	Eyelets FP14-M	14	24	7,8	1.000
1184.1605.0002	Eyelets FP16-M	16	30	9,4	1.000
1184.2005.0002	Eyelets FP20-M	20	34	9,4	1.000
1184.2505.0002	Eyelets FP25-M	25	44	11,2	24.000
1184.4005.0002	Eyelets FP40-M	40	62	12	24.000



BLACK

		A	B	C	MOQ
1184.1005.0040	Eyelets FP10-M	10	18	6,8	1.000
1184.1205.0040	Eyelets FP12-M	12	22	8,1	1.000
1184.1405.0040	Eyelets FP14-M	14	24	7,8	1.000
1184.1605.0040	Eyelets FP16-M	16	30	9,4	1.000
1184.2005.0040	Eyelets FP20-M	20	34	9,4	1.000
1184.2505.0040	Eyelets FP25-M	25	44	11,2	24.000
1184.4005.0040	Eyelets FP40-M	40	62	12	24.000



METAL COATED

		A	B	C	MOQ
1184.1005.0055	Eyelets FP10-M	10	18	6,8	10.000
1184.1205.0055	Eyelets FP12-M	12	22	8,1	10.000
1184.1605.0055	Eyelets FP16-M	16	30	9,4	10.000
1184.2005.0055	Eyelets FP20-M	20	34	9,4	10.000



FEPATEX
circular eyelets

Smarter eyelets, **Cleaner future!**

Recycled. Reliable. Responsible





FM14

Light handpress
Self-piercing eyelets #1 - #5,5

- Manually setting eyelets in PVC banners
- Setting eyelets in one operation

SPECIFICATIONS

Eyelets : Self-piercing #1 t/m # 5,5
Working depth : 10 cm
Weight : 6,6 kg



Brass Nickel Black



FM21

Fast, compact semi-automatic eyelet machine
Eyelets max. 16mm

- Punches hole and setting eyelets in one operation
- Tooling for different eyelet sizes
- Available on table or wheels

SPECIFICATIONS

Eyelets : Max. 16 mm
Capacity : 250 eyelets p/hour
Working depth : 6 cm
Operation : Foot/Hand
Drive : Pneumatic
Weight : 12 kg



Metal eyelets Plastic eyelets



HANDPRESS TOOL

- 4051.0001.NR01 Handpress tool #1
- 4051.0001.NR02 Handpress tool #2
- 4051.0001.NR03 Handpress tool #3
- 4051.0001.NR04 Handpress tool #4
- 4051.0001.NR05 Handpress tool #5,5



SELF-PIERCING EYELETS

- 1550.0100.0002 Eyelets #1 Nickel
- 1550.0200.0002 Eyelets #2 Nickel
- 1550.0300.0002 Eyelets #3 Nickel
- 1550.0400.0002 Eyelets #4 Nickel
- 1550.0550.0002 Eyelets #5,5 Nickel
- 1550.0300.0055 Eyelets #3 Metal Coated



FM35

Professional, heavy semi-automatic eyelet machine
Eyelets max. 66mm

- Punches hole and setting eyelets in one operation
- Easy tool changing to different eyelet sizes
- Large working depth
- Multifunctional
- Wrinkle-free eyelet setting

* Profitex machinetable to be ordered separately

SPECIFICATIONS

Eyelets : Max. 66 mm
Capacity : 250 eyelets p/hour
Working depth : 15 cm
Operation : Foot
Drive : Pneumatic
Weight : 42 kg



Metal eyelets Oval eyelets Plastic eyelets S-hook

FM269

Basis full automatic eyelet machine
Eyelets max. 12mm

- Light and compact full automatic machine
- Automatic feeding of eyelets and washers
- Pneumatic operation

SPECIFICATIES

- Eyelets** : Max. 12 mm
- Capacity** : 1800 eyelets p/hour
- Working depth** : 5 cm
- Speed** : Normal
- Drive** : Pneumatic
- Weight** : 70 kg
- Certification** : CE



Metal eyelets



Plastic eyelets

FM239

High-speed full automatic eyelet machine
Eyelets max. 16mm

- High-speed and efficient full automatic machine
- Automatic feeding of eyelets and washers
- Electric operation
- Low noise & Energy efficient
- Low maintenance

SPECIFICATIES

- Eyelets** : Max. 16 mm
- Capacity** : 3600 eyelets p/hour
- Working depth** : 6 cm
- Speed** : High
- Drive** : Electric 230V
- Weight** : 138 kg
- Certification** : CE



Metal eyelets



Plastic eyelets

FM259

Plastic eyelets



FM269-C

Mobile



FM239-L

Working depth >20cm

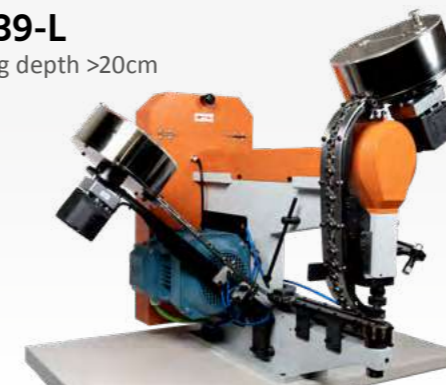

FM239-CF

Mobile





WORKBLADE

- 4299.0269.0042 Workblade 42cm Stainless steel - FM269
- 4299.0239.0042 Workblade 42cm Stainless steel - FM239
- 4299.0000.0080 Workblade extention 80 cm

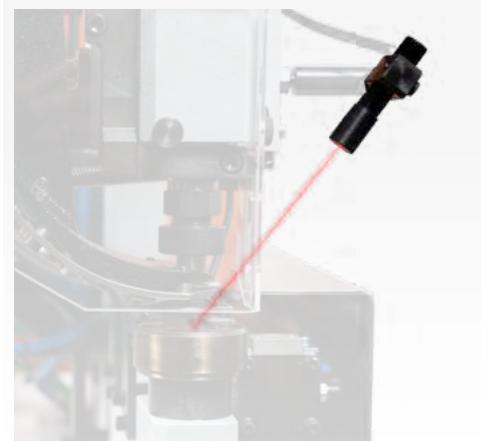

LASER

- 4299.2000.155C-P Laser Pointer
- 4299.2000.155C-L Laser Line
- 4299.2000.155C-K Laser Cross



TRANSPORT FRAME

- 4299.4030.2000 Transport frame for eyelet machines



WORK LIGHTING

- 4299.0000.0005 Tooling LED strip 5cm
- 4299.0000.0006 Work light flex



MEGA HOPPERBOX

- ▶ Automatic bulk feeding of eyelets
- ▶ Increase productivity
- ▶ Less interruptions
- ▶ Debris filtering



VISION SYSTEM

- ▶ Advanced printmark detection
- ▶ Precise eyelet placement
- ▶ Eliminate manual measuring
- ▶ Reduce human errors
- ▶ Large touchscreen interface

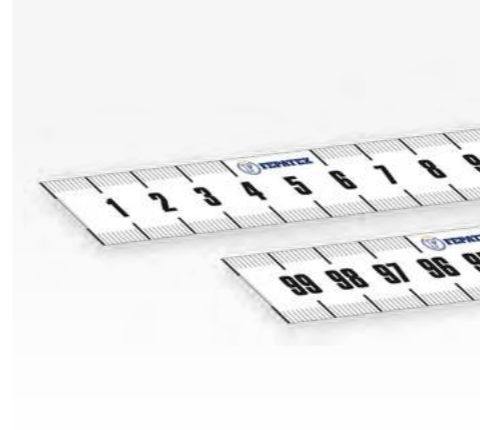

MEASURE TAPES

- 5812.0000.100R Measure tape 100 cm - Adhesive - Left > Right
- 5812.0000.100L Measure tape 100 cm - Adhesive - Right > Left



START/STOP MARKING

- 5812.0000.30SR Start marking 30 cm - Adhesive
- 5812.0000.30ST Stop marking 30 cm - Adhesive

MODULAR CONFECTION TABLES

Shape your workspace

Profitex modular confection tables are designed to meet the needs of modern textile and technical production.

Rolling, Cutting, Welding, Eyeleting or other finishing, these tables let you design a workspace that fits your process.

Profitex tables aren't limited to textile production. They're also perfect for warehouse environments, to use them for assembling work, packing orders or as reliable warehouse and workstation setups.

- ▶ Modular design
- ▶ Create your own workspace
- ▶ Expandable
- ▶ Standing 100cm / Seated 80 cm
- ▶ Machine-ready integration



MODULAR AIR TABLES

Speed up your production process

Profitex Air Tables help you work faster and more comfortable. They are designed for handling large banners, PVC, Mesh and other technical fabrics. The airflow system makes heavy materials float, so you can move them easily, ergonomic and all with one person.

Profitex air tables are strong, ergonomic and designed to last. Thanks to the modular design, you can set them up the way you want and expand any time you need.

Profitex Air Tables are the smart choice for a smooth and efficient workflow. Air tables save time and reduces physical effort during eyeleting, welding, cutting or finishing.

- ▶ Modular design
- ▶ Create your own workspace
- ▶ Adjustable airflow
- ▶ Durable & Ergonomic
- ▶ Machine-ready integration



TURN & BUFFER STATION

Flip, buffer & keep your workflow moving

Profitex Turn Station are designed to flip easily PVC banners, textiles or technical fabrics between different production steps like welding, stitching, eyeleting and rolling. Materials often need to be face-down for welding or stitching, but face-up for applying eyelets or rolling. Profitex Turn Station make it easy to switch quick and effortless.

It also acts as a buffer station, buffering material between production steps to prevent delays in your workflow and reduce manual handling. This improves flow and keeps your production line running smoothly and efficiently.

- ▶ Modular design
- ▶ Easy fabric flipping
- ▶ Buffer function
- ▶ Smooth & efficient workflow
- ▶ Perfect for welding, stitching & eyeleting
- ▶ Optional FlexTop Cover to create more workspace



RAIL CUTTER

Easy and precise cutting

Profitex Rail Cutter is a smart machine for cutting PVC banners and technical textiles quickly and straight. It runs along a fixed rail, which can be made in any length to fit your setup.

The cutter is often placed on a Profitex table, combined with the Easy Cube to unroll the fabric smoothly. Once in place, you simply cut the fabric using the rail cutter. Clean, fast and precise.

You can operate the cutter manually or automatic with a switch on the handle for blade rotation and automatic cutting. It's a compact and reliable solution that makes cutting easier and speeds up your workflow.

- ▶ Always straight cuts
- ▶ Manual or automatic use
- ▶ Custom rail lengths
- ▶ Cutting PVC and technical textiles



T300



T300

Versatile welding for industrial fabrics

T300 Flex is a powerful and flexible welding machine that supports both hot air and hot wedge technology, making it ideal for producing tents, tarps, shelters, and technical covers.

With its easy-to-use touchscreen, fast setup and recipe storage, you can switch between jobs quickly and consistently. Dual welding arms allow for both straight and curved seams, giving you full control over complex shapes and patterns.

Quick and precise head adjustments ensure repeatable, high-quality results, while tool-free guide changes let you switch seam types in minutes. Whether you choose hot air, hot wedge, or a combination of both, the T300 Flex can be customized to fit your production needs.

- ▶ Hot air and hot wedge in one machine
- ▶ Dual arms for seam versatility
- ▶ Quick head adjustments
- ▶ Touchscreen with recipe storage
- ▶ Easy guide changes

112 EXTREME - EasySlide Grommet

112 Extreme



Weld and eyelet in one seamless workflow

112 Extreme is our fastest and most precise solution for long, straight seams, including an integrated eyelet machine for a complete finish in one pass. Custom-built to any length, it's ideal for high-volume production of banners, tarps, and technical textiles.

With touchscreen control of all welding parameters, laser alignment for precise positioning, and a vacuum track that holds material firmly in place, you get consistent, high-quality results every time. The motorized welding head ensures smooth, accurate seams, while the built-in rotary cutter delivers exact cut-to-length finishing.

Thanks to the integrated eyelet unit, you can weld and punch in a single workflow, saving time, reducing handling and increasing output.

- ▶ Welding & eyeleting in one
- ▶ Vacuum track & laser guides
- ▶ Motorized head & rotary cutter
- ▶ Efficient material handling
- ▶ Touchscreen control

HG50 - All in One

All-in-One finish station for automatic banner production

HG 50 is a powerful, compact finishing machine that combines welding, cutting and eyeleting in one single workstation. All operated by just one person.

Designed to speed up banner production, the HG 50 replaces multiple machines and reduces material handling, saving both time and floor space. Its smart, integrated setup streamlines your workflow and increases daily output.

The HG 50 easily welds a wide range of materials, including PVC, mesh, and eco-friendly sign media, making it the perfect choice for printshops and finishing departments that demand speed, precision, and flexibility.

HG 50



PRECISE MATERIAL HANDLING

- ▶ Powered unwind systems and tension control ensure stable material feed.
- ▶ Output puller and top-mounted accumulator enable continuous, uninterrupted processing.

SMART CONTROL & AUTOMATION

- ▶ PLC control with recipe storage for fast, efficient setup.
- ▶ Bi-directional cutting with photo sensors and quick-adjust welding roller for maximum flexibility and minimal downtime.

PRECISE CUTTING & WELDING

- ▶ Optimized for various weld widths and materials.
- ▶ Delivers consistent, high-quality welds across multiple applications.

CUSTOM EYELET SOLUTIONS

- ▶ Accurate grommet placement using integrated photo sensors.
- ▶ Compatible with both metal or plastic eyelets, personalized to your application.

**Weld width may vary depending on the material and application.*

EASY CUBE

Smart & flexible roll handling

Profitex Easy Cubes are a compact, modular solution for rolling and unwinding PVC, foil, textiles or other roll materials. Easy Cubes are available in 40 cm or 80 cm width.

Each cube can be used as a single unit. It is also possible to link each cube in width or length to create a setup that fits your workflow to create a full roll-handling station.

Easy Cube is a smart addition to any workspace where efficient roll handling matters. Strong, space-saving and easy to move.

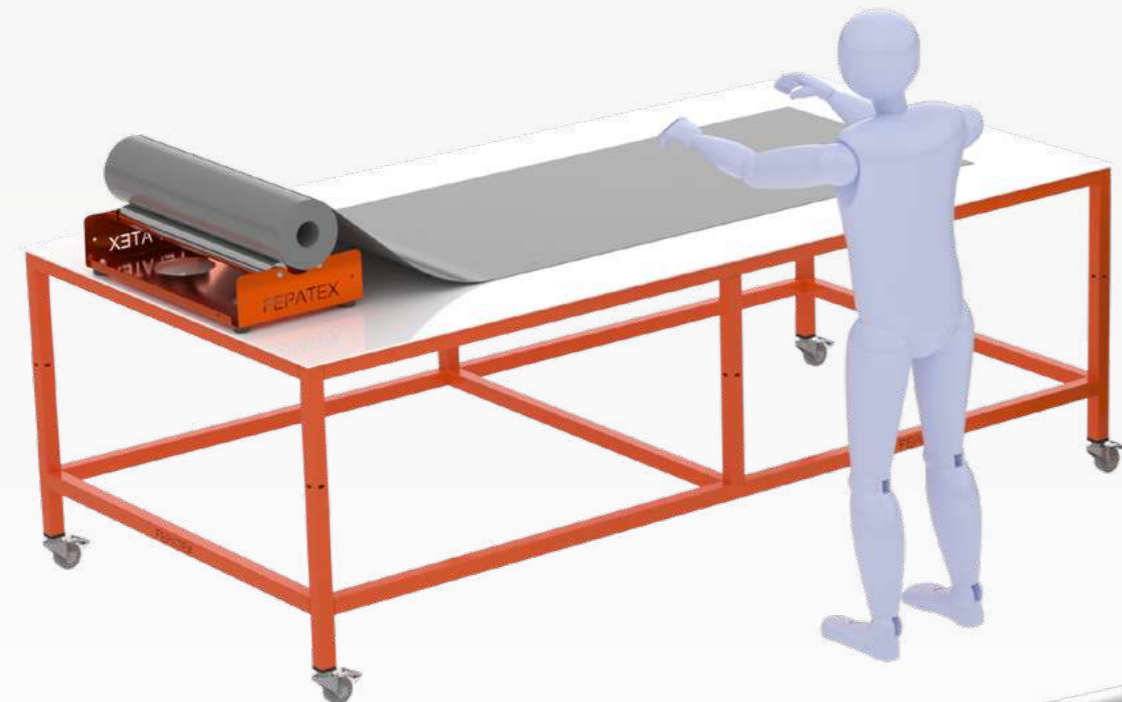

- ▶ Modular cubes
- ▶ Compact & Linkable
- ▶ Easy roll handling
- ▶ Available in 40 cm and 80 cm

ROLL CUBE

Mobile roll handling

Profitex Roll Cubes are a mobile, modular solution for rolling, unwinding and transporting PVC, foil, textiles or other roll materials. Easy Cubes are available in 40 cm or 80 cm width.

You can easily transport rolls across the workspace without lifting. Each cube can be used as a single unit. It is also possible to link each cube in width or length. Roll Cubes give you full control over how you handle and move your media across the workflow.

Roll Cube is a smart addition to any workspace where efficient roll handling matters. Strong, space-saving and easy to move.

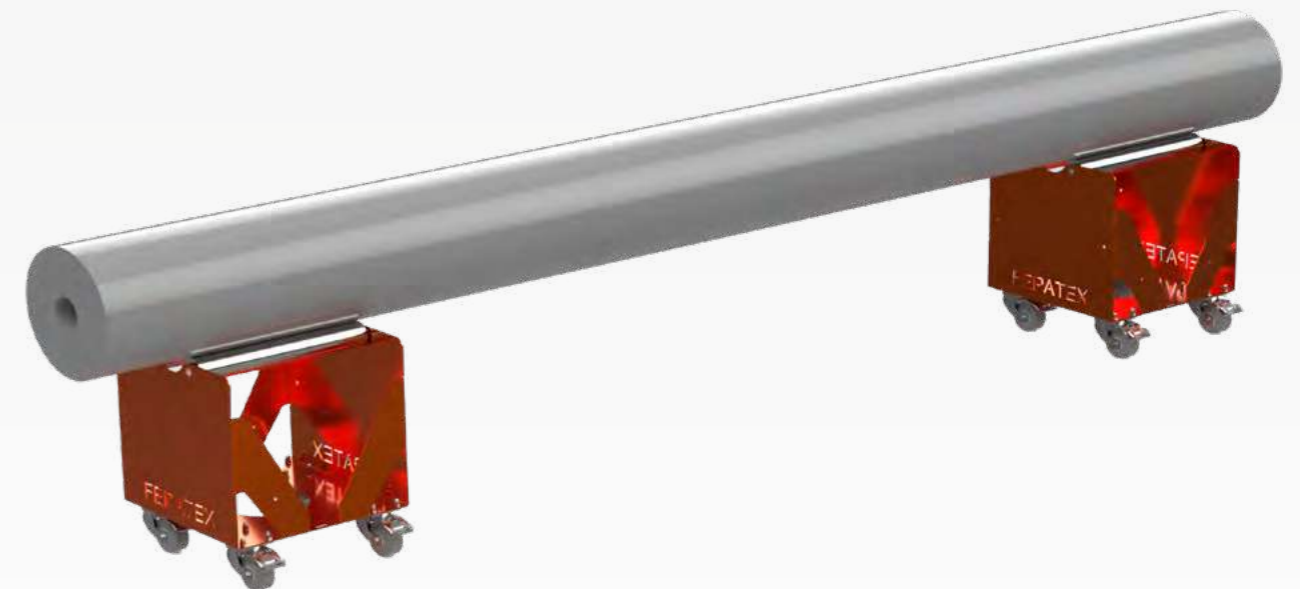

- ▶ Modular roll cubes
- ▶ Mobile & Linkable
- ▶ Easy roll transport
- ▶ Available in 40 and 80 cm

ROLL MOVER 160

Easy and professional handling of heavy rolls

Profitex Roll Mover is a strong and mobile system for rolling, unwinding and moving heavy rolls of PVC, foil, or heavy textiles. Each unit is 160 cm long and can be linked to each other to create a 320 cm setup.

Combined with the Profitex Safety Barrier, the Profitex Roll Mover can be connected to machines such as Zünd cutting systems, creating a practical and ergonomic unwinding solution.



- ▶ Linkable 160 cm to 320 cm
- ▶ Connectable to Safety Barrier
- ▶ Max weight 600 kg (single unit)
- ▶ Swivel wheels with brakes

ROLL TRAY 160

Smart collection tray behind your cutting machine

Profitex Roll Tray is a strong and effective solution to collect or move cut fabric or fabric offcuts. It catches finished pieces as well as scrap material, helping to keep your workspace clean and organized.

Each unit is 160 cm long and can be linked to each other to create a 320 cm setup. Combined with the Profitex Safety Barrier, the Profitex Roll Tray can be connected to machines such as Zünd cutting systems.



- ▶ Linkable 160 cm to 320 cm
- ▶ Connectable to Safety Barrier
- ▶ Max weight 600 kg (single unit)
- ▶ Swivel wheels with brakes

ROLL MASTER

Say goodbye to manual rolling

Profitex Roll Master is our latest professional solution for fast and effortless rolling of banners, PVC, mesh, and textiles.

Designed to handle fabrics with eyelets, hems or zippers. Roll Master delivers clean and tight rolls with minimal effort, without cardboard core.

Roll Master 300 is the perfect solution to roll up standard banners up to 600 cm.

- ▶ Fully motorized rolling
- ▶ Ergonomic design
- ▶ Quick material loading

Available width:

- ▶ RM150, RM200, RM300, RM450, RM600
- ▶ Standard roll up length: 600 cm
- ▶ Customized roll up solutions on request



WALL RACK

Smart roll storage, on the wall

Profitex Wall Rack is a practical and space-saving way to store rolls of PVC, foil, textiles or other materials.

Mounted directly to the wall, these racks keep your rolls organized, protected and off the floor, freeing up valuable workspace. Switching rolls is quick and easy.

Available in 4- or 8-roll versions, Profitex Wall Rack is ideal for printshops, confection workshops and any production area where smart storage matters.

- ▶ Save valuable floor space
- ▶ Quick and easy access
- ▶ Protect rolls from damage
- ▶ Available in 4 and 8 pins rack

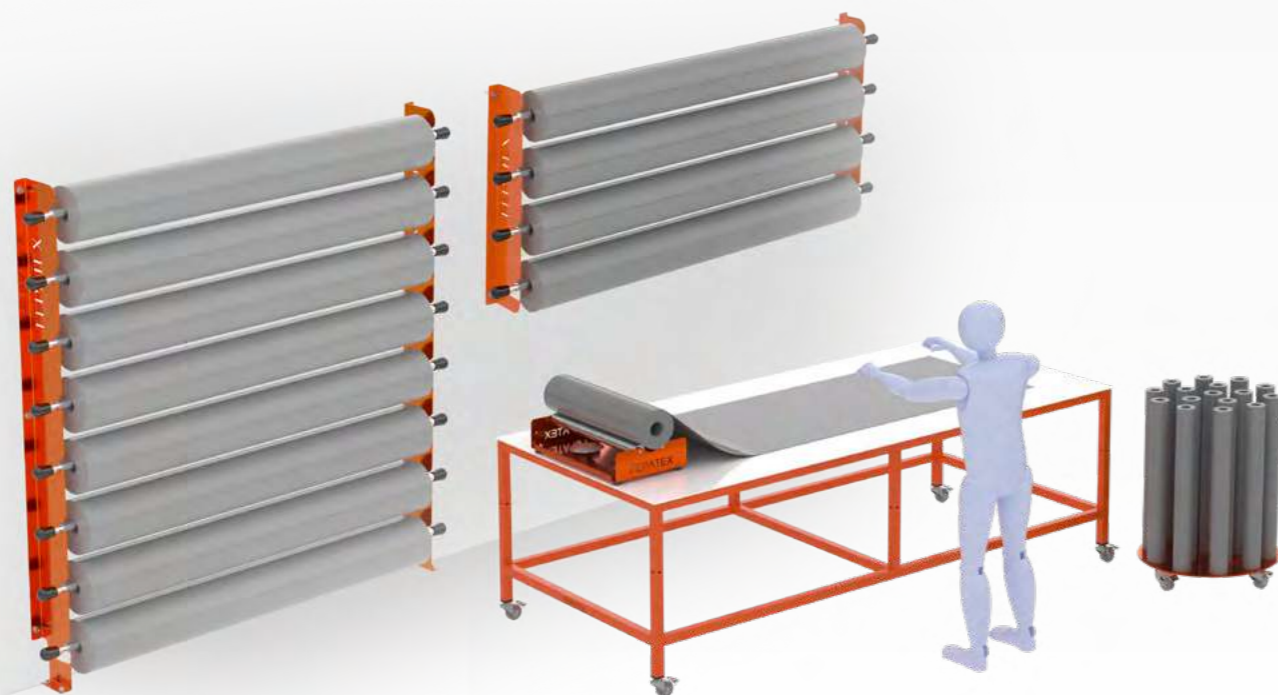

ROLL HOLDER

Store it. Unroll it. Use it.

Profitex Roll Holder is a mobile rack designed for easy storage and unrolling of fabric, webbing, or other rolled materials.

Thanks to its wheels, you can quickly move it to where needed. Next to your machine, table or workstation. The simple design makes it easy to place rolls and unroll them directly.

A practical solution for keeping your materials organized and always ready to use.

- ▶ Mobile and easy to move
- ▶ Direct unrolling from the rack
- ▶ Space-saving
- ▶ Simple and durable



SPIN RACK

Roll storage that moves with you

Profitex Spin Rack is a strong and flexible system for storing and handling media rolls.

Thanks to its modular design, you can easily add or move pins and brackets to fit different roll sizes and uses. Whether you need stable storage or mobile access, Profitex Spin Rack gives you full control over your setup.

Perfect for printshops and production spaces, Spin Rack works with Multi Pins from the Profitex MultiRack range to create a setup that fits your workflow.

- ▶ Rolling storage for media rolls
- ▶ Space-efficient design
- ▶ Quick roll access
- ▶ Spin Rack 40 - 6 pins / Spin Rack 80 - 16 pins
- ▶ Pins 2" - 40cm / 80cm
- ▶ Pins 3" - 40cm



ROLL TOWER

Smart transport & storage solution

Profitex Roll Tower is the smart solution for storing and transporting long products such as PVC rolls, textiles, long tubes or bars.

Use two towers as a standard set to safely transport long items across your workspace.

Handling extra-long materials or heavier loads? Simply add a third tower for enhanced stability and support.

Perfect for both internal transport and organized storage.

- ▶ Max weight: 1500 kg
- ▶ Swivel wheels with brakes



ROLL RACK

Strong, mobile storage for all your media

Profitex Roll Rack is the smart solution for efficient roll storage and easy handling of PVC, media or textiles.

Place your roll rack directly next to your machine to keep rolls within reach and streamline your workflow. Thanks to its mobile design, Roll Rack is easy to move between workstations, making it ideal for internal transport as well.

Roll Rack is available in two versions: 160 cm wide with 10 metal bars and 320 cm wide with 8 metal bars, built for extra-wide materials

Perfect for printshops, textile workshops, and technical production environments.

- ▶ Roll Rack 160 (with 10 bars)
- ▶ Roll Rack 320 (with 8 bars)
- ▶ Max. roll diameter: 30 cm
- ▶ Swivel wheels with brakes



- 1 Profitex Airtables
- 2 Profitex Turn & Buffer Station
- 3 Profitex Easy Cube
- 4 Profitex Rail Cutter
- 5 Miller Weldmaster T300
- 6 Eyeletmachine FM239
- 7 Profitex Roll Master RM300

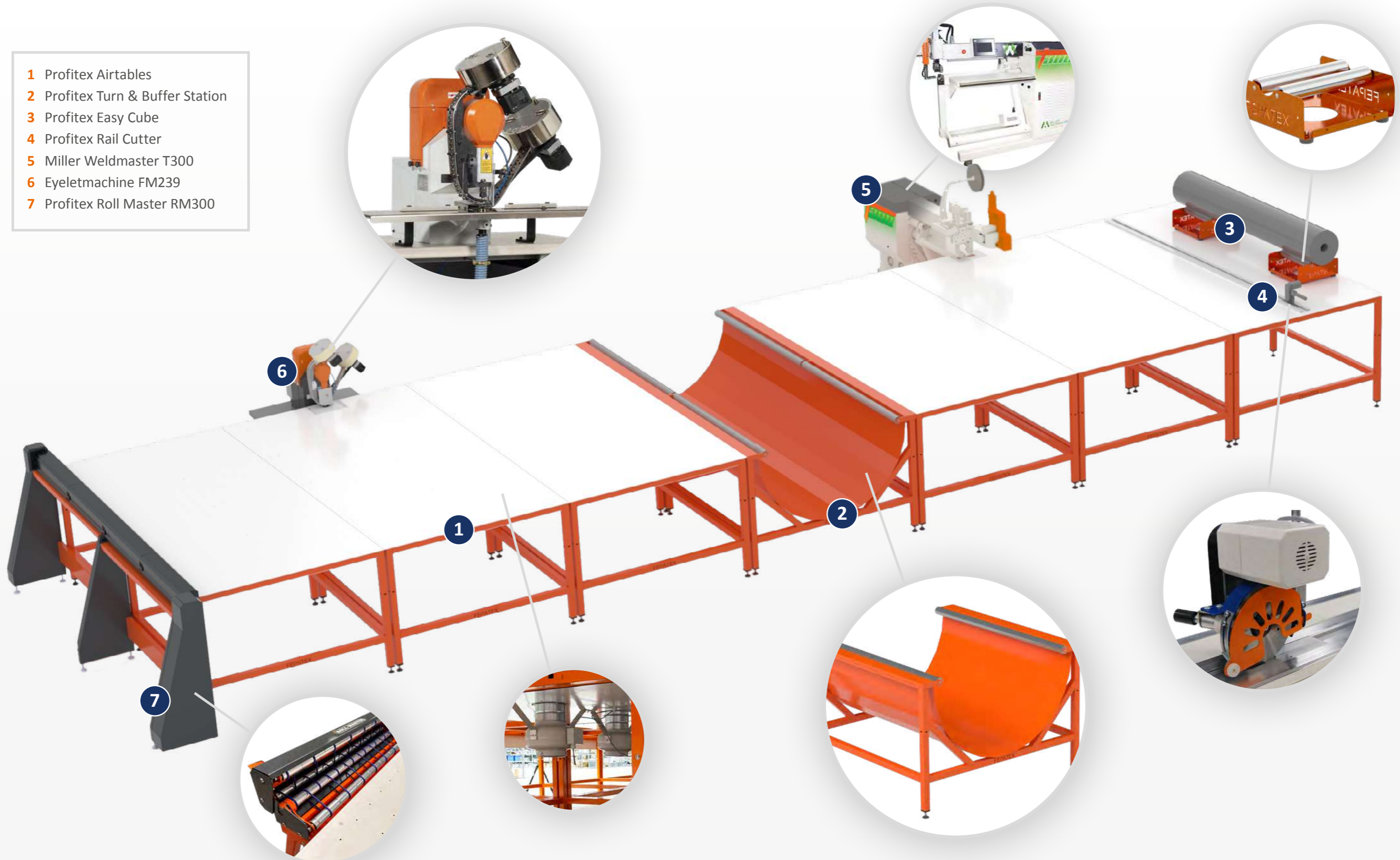

- 1 Profitex Airtables
- 2 Profitex Turn & Buffer Station
- 3 Profitex Roll Mover
- 4 Profitex Rail Cutter
- 5 Miller Weldmaster T300
- 6 Eyeletmachine FM239
- 7 Profitex Roll Master RM450





FEPATEX

Belgiëstraat 18 | 5171 PN Kaatsheuvel | The Netherlands
info@fepatex.nl | +31 (0)416 53 00 49 | fepatex.nl